



## APPLICATIONS

- Warehouses
- Retail
- Agriculture, Food Services
- Gymnasiums
- Convention Centers

## FEATURES

- 100,000 Hour Lifespan (IESNA)
- 10 Year or 60,000 Hour Warranty
- High Pressure Die-casted Aluminum, Powder Coated Gear Box
- Prismatic Acrylic Refractor, Lens
- Optional "Gumdrop" Style w/ Aluminum Reflector
- Hook or Pendant Installation
- Ambient Temp Range: -30 to 120 deg F

Made in the USA   
of U.S. and imported parts



## LAMP/GENERATOR

- 120-277V Universal Electronic Ballast
- Available 0-10V Dimmability, 2-way Communication
- Power Factor > 0.95, Operation Frequency 50-60Hz
- Instant-On, Flicker Free, Minimum Light Loss
- 80W—400W Round Tubular Lamp Design
- Color Temps Available: 3000K—5000K
- CRI > 85—Excellent Color Rendition



"Gumdrop" Style

Product #	Wattage	Replaces	Lm/W	Lumens	IP Rating	Size	Lens
MHT-LB-80E	80	MH - 150W HPS - 150W	77.5	6,200	43 (gear box)	16"	Prismatic Acrylic
MHT-LB-100E	100	MH - 200W HPS - 200W	77.5	7,750	43 (gear box)	16"	Prismatic Acrylic
MHT-LB-120E	120	MH - 200W HPS - 200W	77.5	9,300	43 (gear box)	22"	Prismatic Acrylic
MHT-HB-150E	150	MH - 250W HPS - 300W	82.5	12,375	43 (gear box)	22"	Prismatic Acrylic
MHT-HB-200E	200	MH - 360W HPS - 400W	82.5	16,500	43 (gear box)	22"	Prismatic Acrylic
MHT-HB-250E	250	MH - 400W HPS - 500W	87.5	21,875	43 (gear box)	22"	Prismatic Acrylic

### Available Options:

- Dimmable Ballast
- Wall Step Dimming Switch, Remote Control
- Cord & Plug, Wireguard, Safety Cable

### ORDERING CODES

MHT-_____	-	_____ E	-	_____	-	_____	-	_____	-	_____
<b>HB = High Bay</b> <b>LB = Low Bay</b>		<b>Wattage:</b> 80, 100, 120, 150, 200, 250		<b>Color Temp:</b> 3K = 3000K 4K = 4000K 5K = 5000K		<b>Voltage:</b> U = Universal 3 = 347V		<b>Dimmable</b> <b>Ballast:</b> DB		<b>Options:</b> WG = Wireguard, CP = Cord & Plug, SC = Safety Cable SW = Dim Switch, RC = Remote Control

### DIMENSIONS

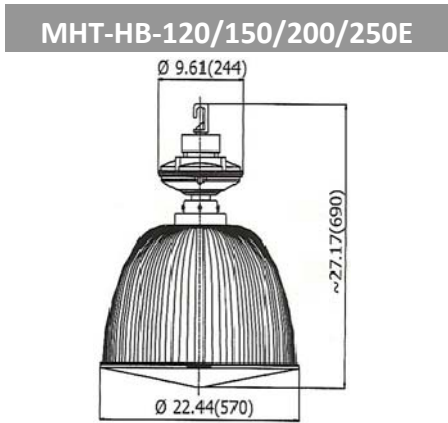
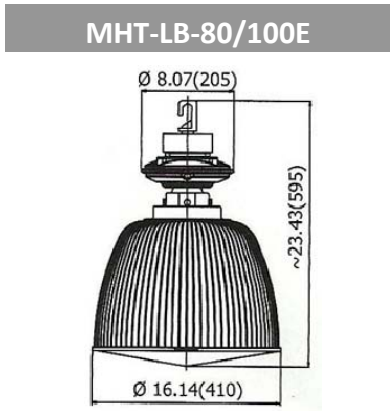

### SAMPLE PHOTOMETRICS

**MHT-HB-100E**

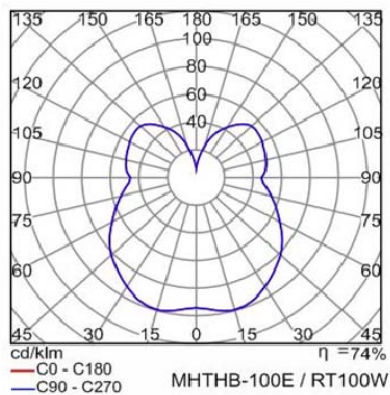

**MHT-HB-200E**

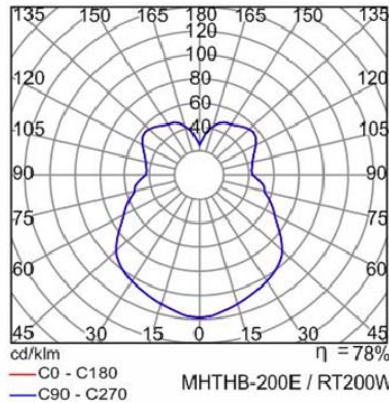

**MHT-HB-250E**

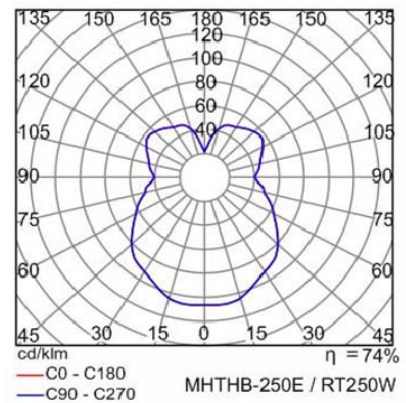

- Products are UL Listed/Labeled and Assembled in ISO9000/1 Certified US Facility
- Every product is quality tested and inspected prior to shipment
- We offer a 10-year, 60,000 hour Warranty (please see Warranty Terms and Conditions)
- Made in the USA of US and Imported Parts, Meets Buy American requirements within the ARRA