



### APPLICATIONS

- RETROFITS
  - Shoebox
  - Flood Lights
  - Specialty Fixtures
  - Indoor Linear Fixtures

### FEATURES

- 100,000 Hour Lifespan (IESNA)
- 5 Year or 30,000 Hour Warranty
- Square Profiled or Die-Casted Aluminum Ballast Housing
- Includes Mounting Hardware
- Ambient Temp Range: -30 to 120 deg F



### LAMP/GENERATOR

- 120-277V Universal Electronic Ballast
- Available 0-10V Dimmability, 2-way Communication
- Power Factor > 0.95, Operation Frequency 50-60Hz
- Instant-On, Flicker Free, Minimum Light Loss
- 40W—400W Square Tubular Lamp Design
- Color Temps Available: 3000K—5000K
- CRI > 85—Excellent Color Rendition



Product #	Wattage	Replaces	Lm/W	Lumens	Voltage	Current (A)	Input Pwr (W)
MHT-ST-40E	40	MH - 70W HPS - 100W	72.5	2,900	120/277	0.16 - 0.35	42
MHT-ST-55E	55	MH - 100W HPS - 100W	72.5	3,988	120/277	0.21 - 0.49	58
MHT-ST-70E	70	MH - 120W HPS - 150W	72.5	5,075	120/277	0.27 - 0.62	74
MHT-ST-80E	80	MH - 150W HPS - 150W	77.5	6,200	120/277	0.32 - 0.70	84
MHT-ST-100E	100	MH - 200W HPS - 200W	77.5	7,750	120/277	0.40 - 0.93	105
MHT-ST-120E	120	MH - 200W HPS - 200W	77.5	9,300	120/277	0.45 - 1.05	126
MHT-ST-150E	150	MH - 250W HPS - 300W	82.5	12,375	120/277	0.59 - 1.36	158
MHT-ST-200E	200	MH - 360W HPS - 400W	82.5	16,500	120/277	0.77 - 1.79	210
MHT-ST-250E	250	MH - 400W HPS - 500W	87.5	21,875	120/277	1.05 - 2.19	263
MHT-ST-300E	300	MH - 500W HPS - 500W	87.5	26,250	120/277	1.20 - 2.63	315
MHT-ST-400E	400	MH - 1000W HPS - 1000W	87.5	35,000	120/277	1.44 - 3.33	420

#### Available Options:

- Dimmable Ballast

## ORDERING CODES

**MHT-ST**
**E**

**Wattage:**  
 40, 55, 70, 80, 100,  
 120, 150, 200, 250,  
 300, 400

**Color Temp:**  
 3K = 3000K  
 4K = 4000K  
 5K = 5000K

**Voltage:**  
 U = Universal  
 3 = 347V

**Dimmable  
 Ballast:**  
 DB

## DIMENSIONS

### LAMP DIMENSIONS

<i>inches (mm)</i>	<b>Dia</b>	<b>W</b>	<b>L</b>
<b>MHT-ST-40E</b>	1.7 (42)	4.5 (114)	8.1 (204)
<b>MHT-ST-55E</b>	1.7 (42)	4.5 (114)	8.1 (204)
<b>MHT-ST-70E</b>	2.1 (54)	5.5 (140)	9.9 (250)
<b>MHT-ST-80E</b>	2.1 (54)	5.5 (140)	9.9 (250)
<b>MHT-ST-100E</b>	2.1 (54)	5.5 (140)	11.8 (300)
<b>MHT-ST-120E</b>	2.1 (54)	5.5 (140)	13.4 (340)
<b>MHT-ST-150E</b>	2.1 (54)	5.5 (140)	15.4 (390)
<b>MHT-ST-200E</b>	2.3 (58)	7.4 (186)	17.3 (438)
<b>MHT-ST-250E</b>	2.3 (58)	7.4 (186)	23.2 (588)
<b>MHT-ST-300E</b>	2.3 (58)	7.4 (186)	27.1 (688)
<b>MHT-ST-400E</b>	2.3 (58)	7.4 (186)	35.0 (888)

### BALLAST DIMENSIONS

<i>inches (mm)</i>	<b>L</b>	<b>W</b>	<b>H</b>
<b>MHT-ST-40E</b>	7.0 (177)	4.1 (105)	1.9 (48)
<b>MHT-ST-55E</b>	7.0 (177)	4.1 (105)	1.9 (48)
<b>MHT-ST-70E</b>	7.0 (177)	4.1 (105)	1.9 (48)
<b>MHT-ST-80E</b>	7.0 (177)	4.1 (105)	1.9 (48)
<b>MHT-ST-100E</b>	7.0 (177)	4.1 (105)	1.9 (48)
<b>MHT-ST-120E</b>	8.4 (213)	4.8 (120)	2.1 (53)
<b>MHT-ST-150E</b>	8.4 (213)	4.8 (120)	2.1 (53)
<b>MHT-ST-200E</b>	8.4 (213)	4.8 (120)	2.1 (53)
<b>MHT-ST-250E</b>	12.6 (319)	7.5 (190)	3.0 (76)
<b>MHT-ST-300E</b>	12.6 (319)	7.5 (190)	3.0 (76)
<b>MHT-ST-400E</b>	12.6 (319)	7.5 (190)	3.0 (76)

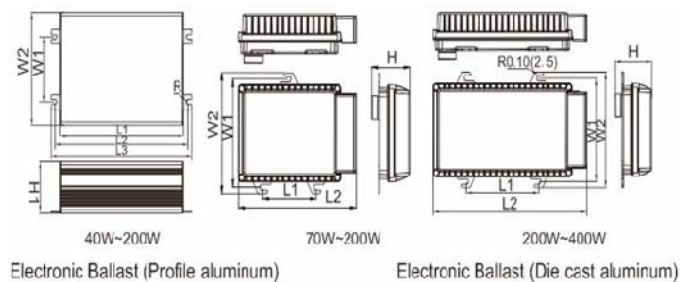
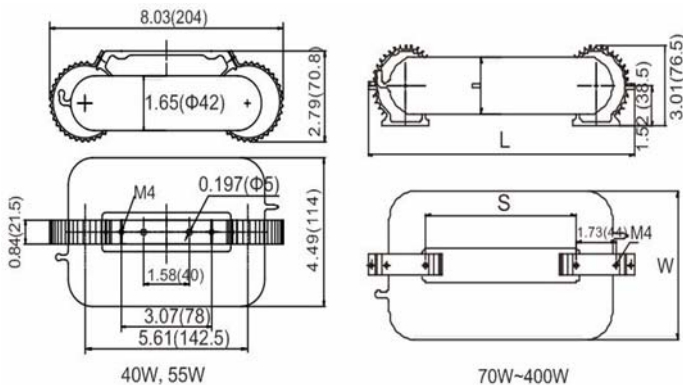

Electronic Ballast (Profile aluminum)

Electronic Ballast (Die cast aluminum)

- Products are UL Listed/Labeled and Assembled in ISO9000/1 Certified US Facility
- Every product is quality tested and inspected prior to shipment
- We offer a 5-year, 30,000 hour Warranty on most retrofits

\*\* Please see Warranty Terms and Conditions for details